

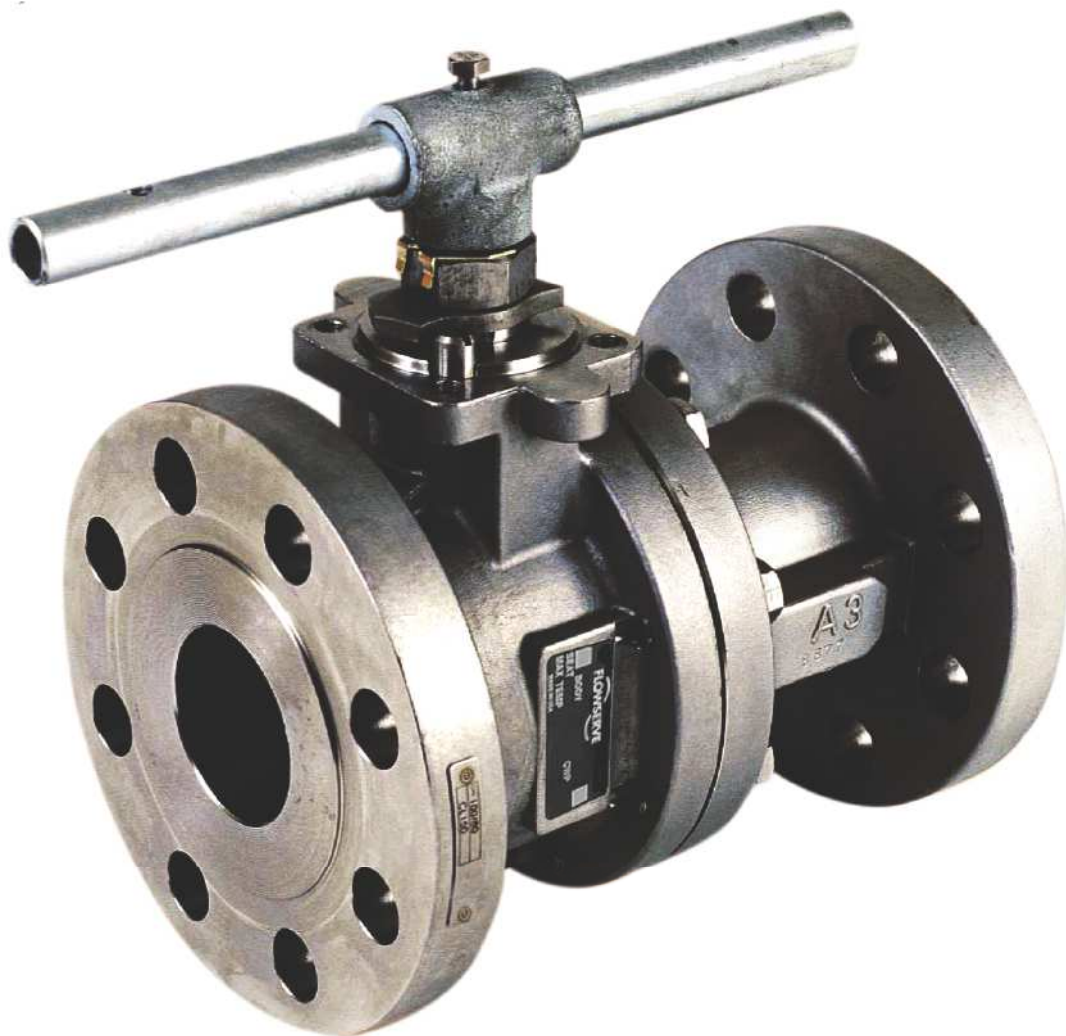

TECHNICAL BULLETIN

Audco Ball Valve

Full Bore Firesafe Flanged Ball Valves 819 / 829 Series



With the Series 819/829 designed to BS EN ISO 17292 / API 6D, AUDCO brings to the market a full bore valve which combines low cost of ownership and long service life with high operational safety and a range of features which sets the standards for others to follow.

What remains unchanged however is Audco's total dedication to quality and service support. All of this is the result of following one simple strategy - to listen and respond to the needs of our customers.

819/829 Valve Assembly

Anti-blowout stem - Inserted from inside of valve body for greater safety

Actuator mounting - Conforms to ISO 5211 for ease of actuation

Anti-static stem - Ensures electrical continuity between ball and body

Ball - 316 stainless steel as standard with pressure equalising hole to balance cavity pressure with line pressure when valve is open. Parallel ported ball maximises flow and minimises pressure drop

Body seals - PTFE coated graphite as standard for firesafe integrity, eliminates media contamination.

Seat design - Cavity pressure relieving (CPR) seats ensure that pressure generated through media expansion when the valve is closed is safely relieved upstream

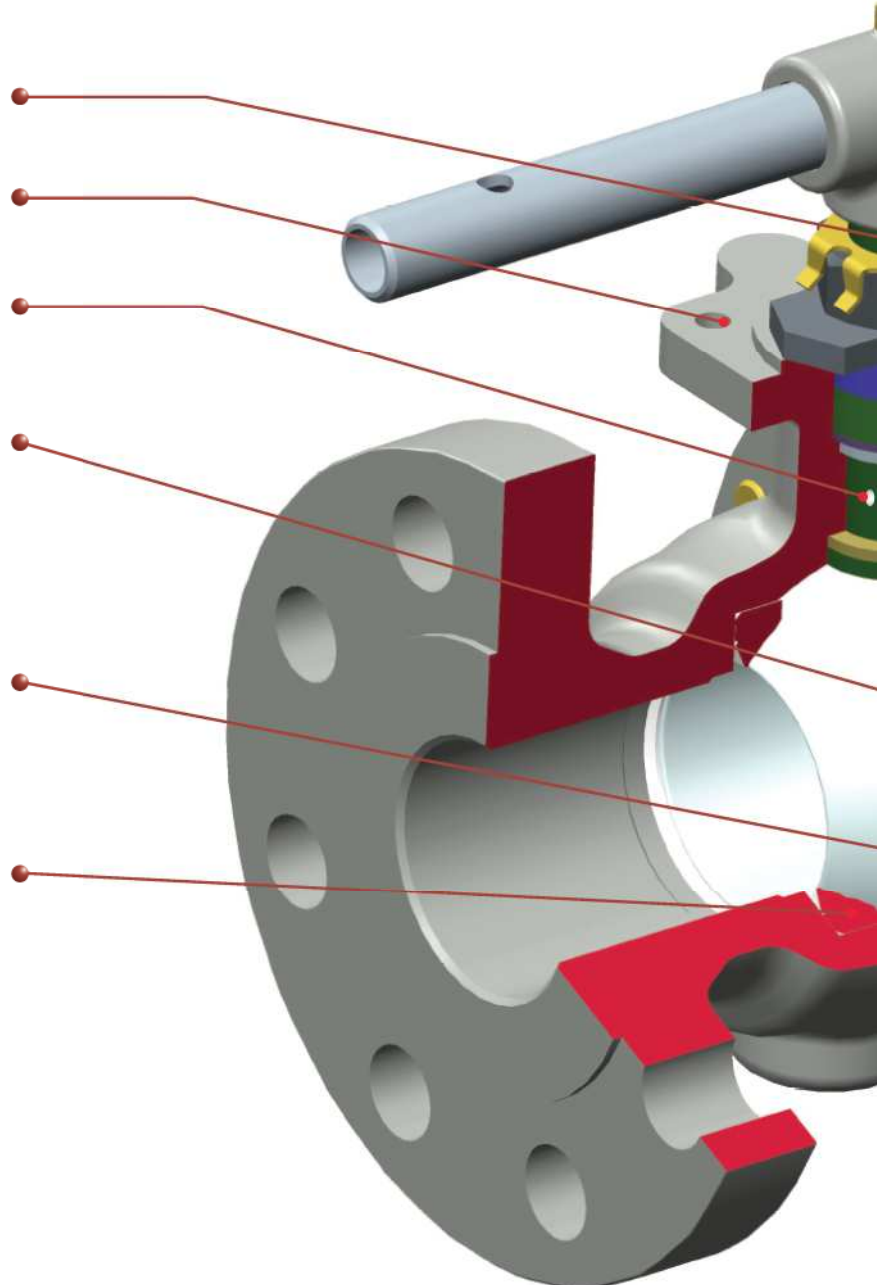

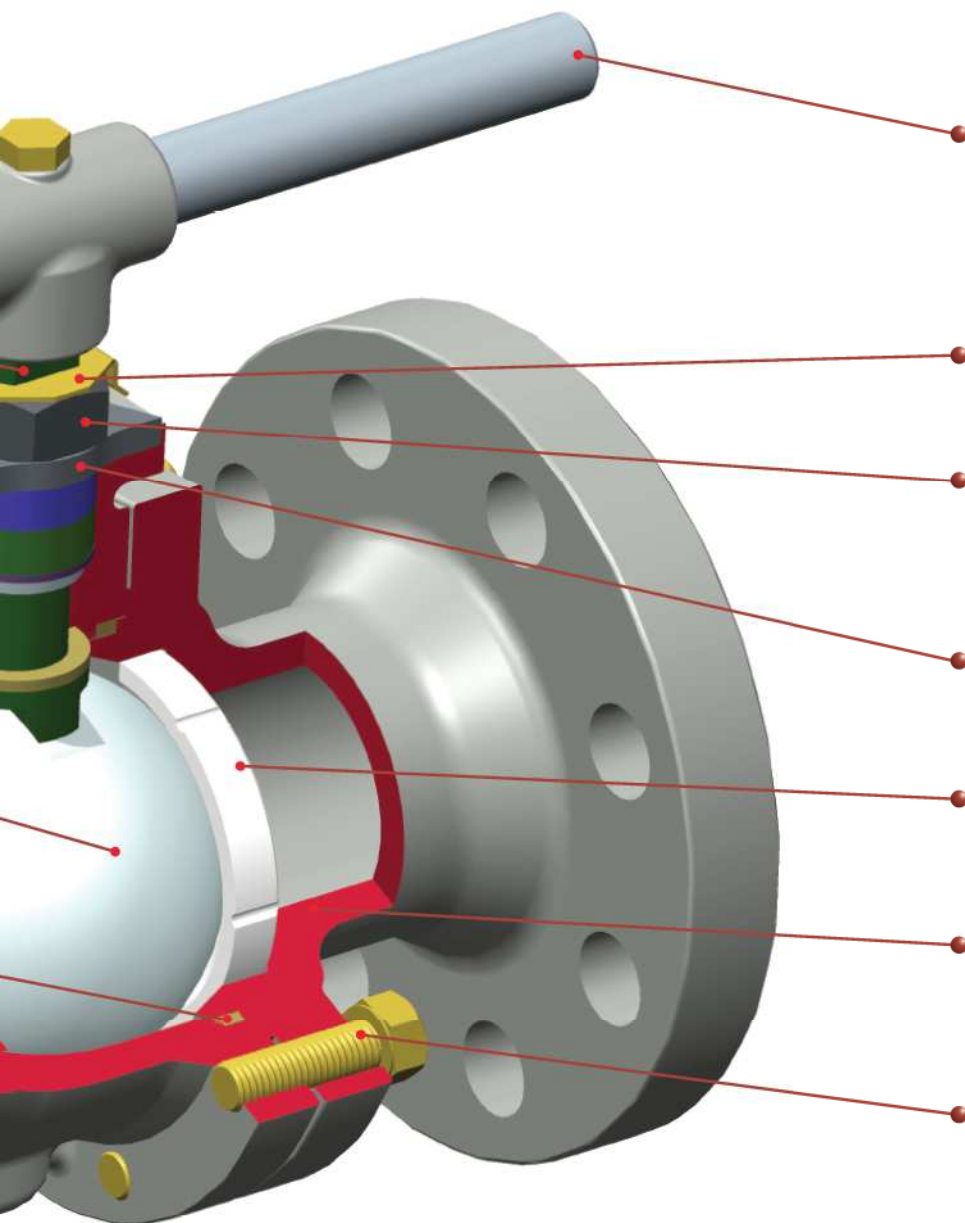

Wrench - Wrench can be fitted at mid or end position to suit space requirements

Locking clip - Maintains position of gland nut during actuation for long leak-free performance

Gland nut - Does not need to be removed for actuator mounting thereby maintaining valve integrity

Stop Plate - Remains fitted during actuation for visual indication of ball position

Seats - Wide range of seat materials to suit customer applications

Materials of construction - Body and end connector are manufactured from cast or wrought material. All valves are supplied with stainless steel interflange bolting.

Bolting - To meet the requirements of ASME VIII: Div.1 pressure vessel codes

Parts/Materials List

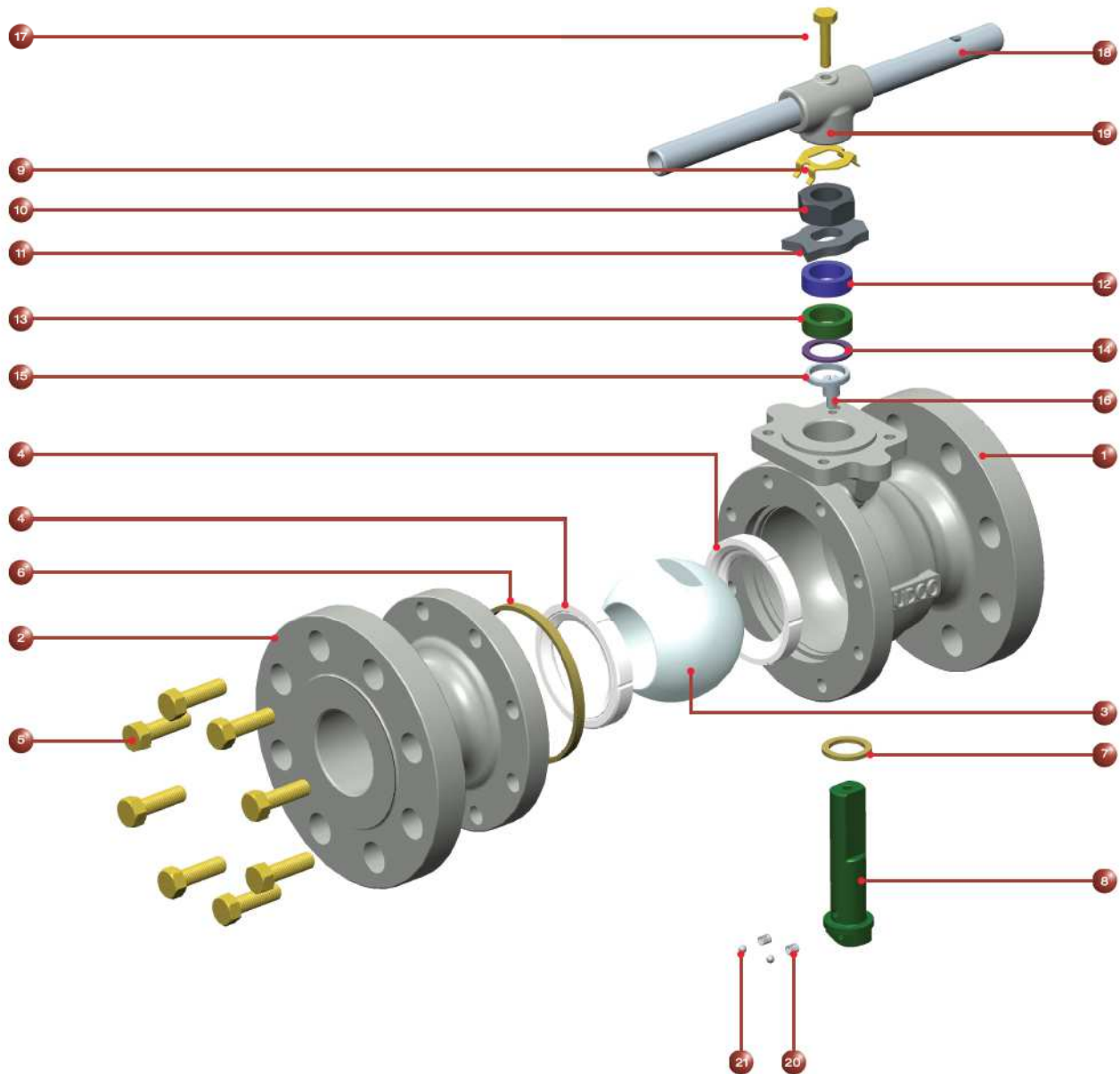

ITEM	DESCRIPTION	MATERIAL	ITEM	DESCRIPTION	MATERIAL
1&2	Body & Body Connector	Stainless Steel ASTM-A351 CF8M/ Carbon Steel ASTM A216 WCB	11	Stop Indicator	Stainless Steel 316 / Zinc Plated Carbon Steel
3	Ball	Stainless Steel ASTM A351 CF8M or ASTM A479 316	12	Gland	Stainless Steel 316
4*	Seat	PTFE Virgin, PTFE 25% glass filled, Fluorofill, PEEK, metal or other options (see page 5)	13*	Gland Packing	Flexible Graphite
5	Body Connector Screw	Stainless Steel ASTM A193M Grade B8M CL 2 ASTM A193M Grade B7	14	Stem Location Ring	Stainless Steel 316
6*	Body Seal	Flexible Graphite	15	Secondary Stem Seal	Virgin PTFE
7*	Stem Thrust Seal	Re-inforced PTFE	16	Stop Pin	Stainless Steel / Carbon Steel
8	Stem	Stainless Steel Type 316	17	Wrench Fixing Bolt	Carbon Steel
9*	Gland Nut Locking Clip	Stainless Steel / Carbon Steel	18	Wrench	Stainless Steel / Carbon Steel
10	Gland Nut	Zinc Plated Stainless Steel / Carbon Steel	19	Wrench Head	S.G Iron / Zinc Plated Carbon Steel / Carbon Steel
			20	Anti-static Spring	Stainless Steel
			21	Anti-static Plunger	Stainless Steel

* Items marked thus denote component supplied in repair kit

Pressure/Temperature Ratings

PTFE

Virgin PTFE is the most common sealing material and is suitable for almost all media as it has excellent chemical resistance.

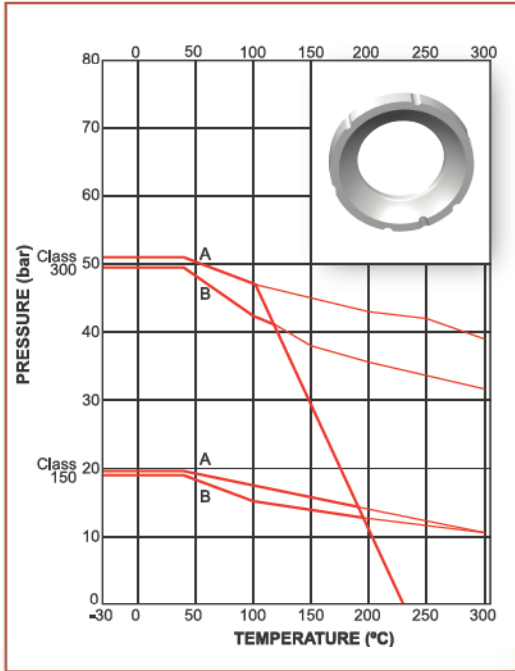

25% GLASS FILLED PTFE

Glass re-inforced PTFE material offering a greater pressure / temperature capability.

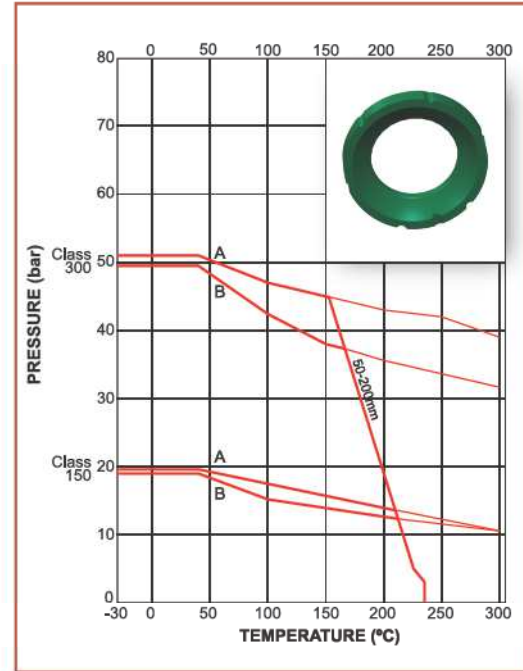

PEEK

PEEK is PolyEther Ether Ketone, a material which demonstrates outstanding pressure capabilities at elevated temperatures. PEEK has excellent chemical and abrasion resistance.

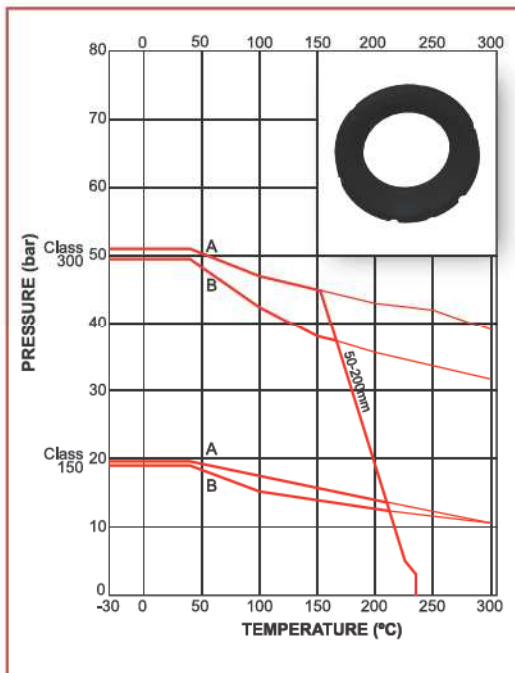

POLYFILL

Carbon, glass and graphite filled PTFE material, an excellent seat material for steam and thermal services. Due to its high cycling capabilities, it is the recommended soft seat for modulating control applications.

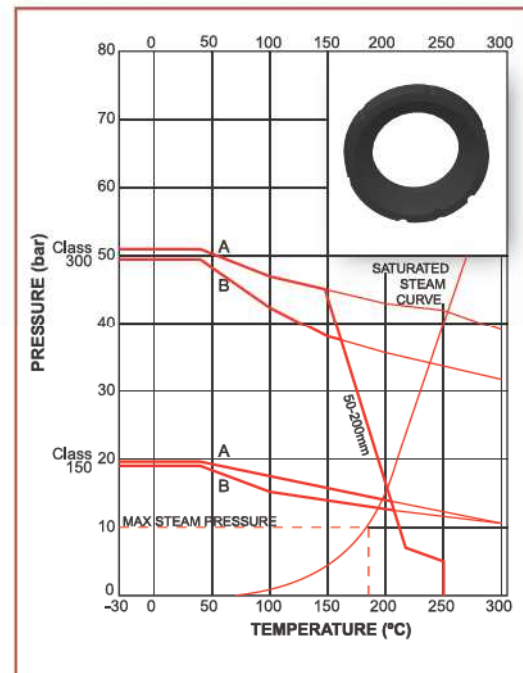

A = Carbon Steel Body Rating, B = Stainless Steel Body Rating (in accordance with ASME B 16.34)

General Assembly

819 series - Full bore class 150

829 series - Full bore class 300

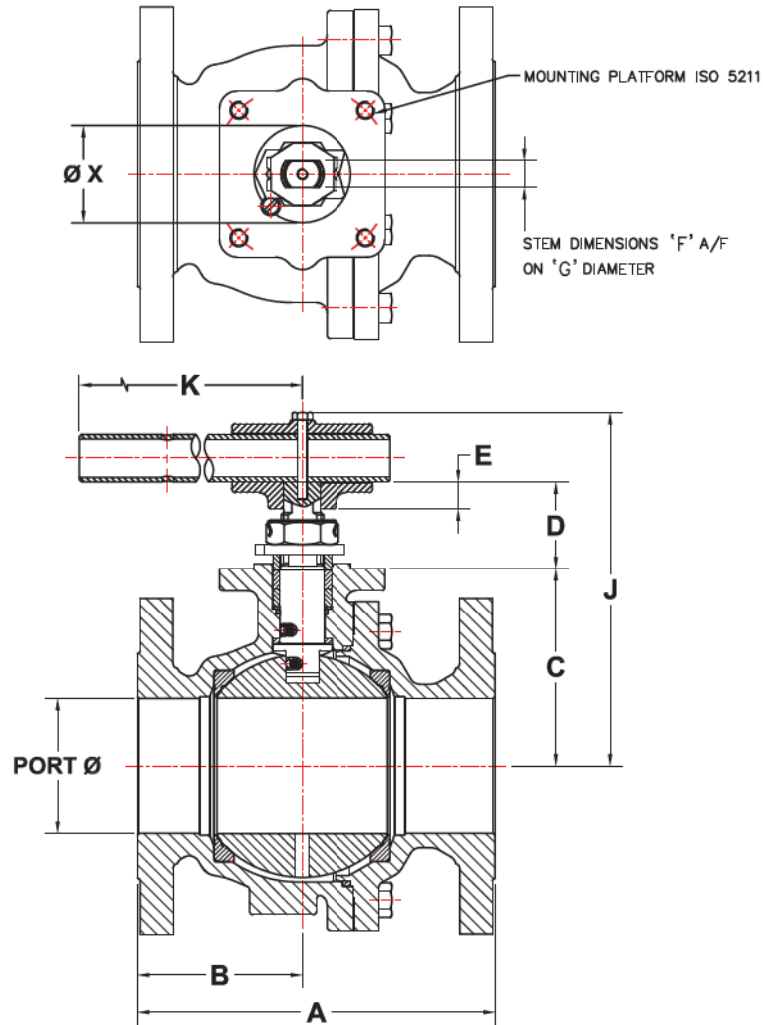

Valve Dimensions (mm)

Valve Size (Port Ø)	819 (CL.150)										829 (CL.300)											
	A	B	C	D	E	F A/F MAX	G Dia. MAX	J	K	X Dia.	ISO MTG	A	B	C	D	E	F A/F MAX	G Dia. MAX	J	K	X Dia.	ISO MTG
DN50 (51.1)	178	74	87.6 86.9	43.8 41.5	-	14.0	M20x 1.5p	156	225	55.0	F07	216	74	87.6 86.9	43.8 41.5	-	14.0	M20x 1.5p	156	225	55.0	F07
DN65 (64.0)	190	77	101.7 101.3	51.1 48.4	17.2	15.1	21.1	190	350	55.0	F07	241	93	101.7 101.3	51.1 48.4	17.2	15.1	21.1	190	350	55.0	F07
DN80 (76.5)	203	94	112.4 111.6	51.1 48.4	17.2	15.1	21.1	201	350	55.0	F07	283	94	119.9 119.1	55.7 53.0	21.4	19.3	27.2	214	557	70.0	F10
DN100 (102.3)	229	117	140.6 139.8	55.9 53.2	21.4	19.3	27.1	235	557	70.0	F10	305	132	147.1 146.3	73.0 70.3	28.6	26.6	33.2	275	850	85.0	F12
DN150 (152.4)	394	179	182.4 181.6	73.0 70.3	28.6	26.6	33.1	310	850	85.0	F12	403	179	194.6 193.8	77.4 74.7	29.6	30.4	37.9	327	850	100.0	F14
DN200 (203.3)	457	206	237.4 236.6	77.4 74.7	29.6	30.4	37.8	-	-	100.0	F14	502	231	256.2 255.3	88.4 85.5	36.0	34.5	42.6	-	-	130.0	F16

How to Order

Valve Size	Operator	Bore	Product series	Body / Connector	Ball & Stem	Seats	Body Seal	Ends
20 - DN50	L - Lever / Wrench	F – Full bore	819	4 - Carbon steel	4 - Carbon steel	T - PTFE	T - PTFE	F1 - ASME B16.5 CL.150
25 - DN65	G - Gear		829	6 - 316 S.S	6 - 316 S.S	R - RPTFE	G - Graphite	F2 - ASME B16.5 CL.300
30 - DN80	B - Bare stem for actuation					P - Polyfill		
40 - DN100	A - Actuator							
60 - DN150								
80 - DN200								

For any other additional requirement please specify.

Ordering Example:

A valve size DN50 Series 819 with Cast steel body and connector, 316 ball and stem, PTFE seats and seals with flanged ends class 150 Lever operated. The catalogue numbering shall be **“20LF-81946TT-F1”**

Notes

1. When wrench not fitted, flats on stem when parallel to pipeline axis denote open position.
2. Installation, Operating and Maintenance instructions are supplied with product and also available on request.
3. Limiting stem input torque figures are based on random practical laboratory tests. For critical applications where a guaranteed figure is essential, consult technical sales.

Standards of Compliance

Valve Specification	BS EN ISO 17292, API 6D
Flanges 819	ASME B16.5 Class 150
Flanges 829	ASME B16.5 Class 300
Face to Face Lengths	ASME B16, 10 Long Pattern
Pressure Test Specification	BS EN 12266 Part 1
Firesafe Specification	API 607
Sour Gas Applications	NACE MR0175/ISO 15156

Technical Information

Valve Size (mm)	Series	Weight Kg	Limiting Stem input Torque - Nm (see note 3)	Valve Operating Torque*	Flow Coefficients	
					Cv	Kv
DN 50	819	12.0	192	35	501	423
	829	15.0		50		
DN 65	819	20	336	130	800	683
	829	24		150		
DN 80	819	22.0	336	165	1158	978
	829	32.0	620	300		
DN 100	819	40.0	620	330	2118	1789
	829	57.0	1138	675		
DN 150	819	88.0	1138	500	5074	4287
	829	117.0	2006	1020		
DN 200	819	176.0	2006	1430	9337	7889
	829	236.0	2910	2030		

*Valve operating torques at full differential pressure with PTFE Seats

Cv - Flow in US GPM Pressure - psi
Kv - Flow in m³/hr Pressure - bar