

OIL PREPARATION UNITS

SAIFEE COMBUSTION EQUIPMENT

SPH DPH DPDH

SAIFEE OIL PUMPING AND HEATING

UNITS supply fuel oil at a predetermined constant pressure and temperature to ensure efficient combustion. These compact units prevent undesirable variations in temperature caused by heat loss and varying rates of oil flow in long oil lines from heaters located at considerable distances.

SIMPLEX MODEL SPH

One motorized rotary gear oil pump, one preheater and two simplex filters (one fitted in line, the other supplied loose to be fitted in outgoing line).

DUPLEX MODEL DPH

Two motorized rotary gear oil pumps (one working and one standby), one preheater and two simplex filters (one fitted in line, the other supplied loose to be fitted in the outgoing line).

SPH and DPH can be ordered with optional duplex filter at extra cost.

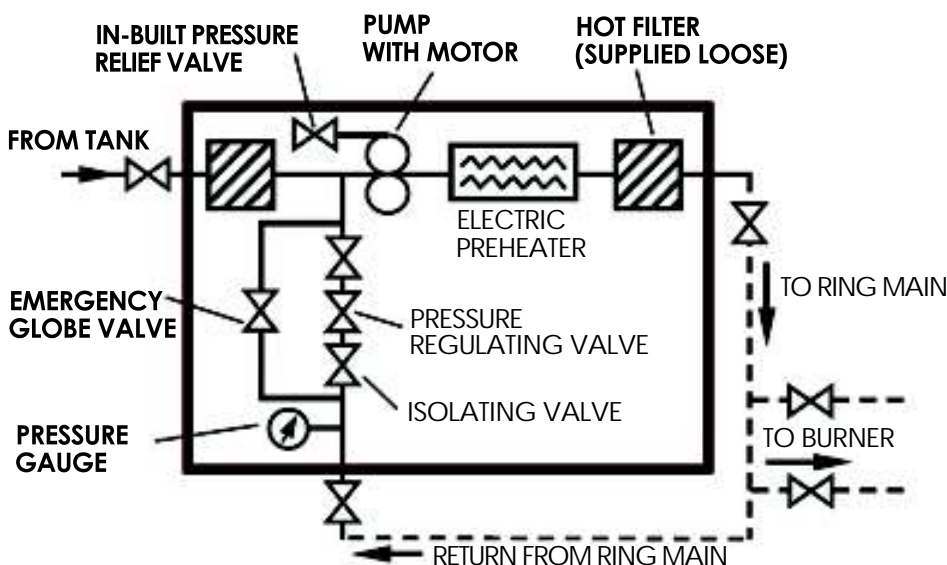

DUPLEX MODEL DPDH

Two motorized rotary gear oil pumps and two preheaters (while one set of pumps and preheaters is operating, the other set acts as a standby) with in-built three-way duplex filters.

Saiffee Pumping and Heating unit are generally manufactured as per the schematic shown on the left. The components are mounted on an MS tray and the units are supplied complete with necessary interconnecting pipe work.

Standard units are available in sizes from 1 kW to 90 kW. Non-standard units can be designed on request.

SAIFEE ENGINEERING INDUSTRIES

T35A BIPLABI RASH BIHARI BASU ROAD KOLKATA 700001, INDIA TEL: +91 (33) 40245786 MOBILE: +91 9883038252
EMAIL: saiffeeengind@gmail.com WEBSITE: www.saiffeeeng.com WHATSAPP: +91 9883038252
Information in this document is non-binding and subject to modification