

DUAL FUEL BURNERS

SERIES 6114

SAIFEE COMBUSTION EQUIPMENT

SAIFEE 6114 DUAL FUEL BURNERS are sealed-in burners for burning gas, light or heavy oil for wide variety of applications. Capable of efficient operation throughout a wide range of preheat air temperature. These are equally stable on low temperature ovens and high temperature furnace such as reheating, forging, melting, hot air generators etc. Sealed mountings prevents unwanted air from the atmosphere entering the burner which helps to maintain furnace pressure, controlled atmosphere, and better gas/ air ratio. Thus better product quality is achieved.



COMBUSTION CHARACTERISTIC

OIL: Oil viscosity at the burners should not exceed 100 SSU. Minimum atomizing air pressure at the burner is 70 mbar for light oil and 100 mbar for heavy oil.

GAS: Atomizing air at minimum 15 mbar should be allowed to keep atomizer cool. Gas pressure should not be more than 130 mbar before the air gas ratio regulator. Gas pressure should be equivalent to air pressure at the burner inlet.

6114 Burners are stable with 100% or more excess air. 6114 Burners can be turned down to atomizing air only, but stability limits vary depending on burner size and grade of oil. For prolonged operation on atomizing air only in furnaces over 850°C, specify an

alloy burner nose. Please consult Saifee regarding minimum oil rates for your specific application. Burners are suitable for preheated combustion air up to 350°C.

FLAME SUPERVISION UV Flame sensor can be used at the provision provided on the burner body.

IGNITION Saifee pilot burner can be used for auto ignition. Pilot operation should be interrupted after few seconds.

JACKETED TILES Burner tile of cast refractory are used. Steel jacketed are used around the tile for applications where the tile is not supported by furnace refractory like ceramic lining.

MODEL	A	B	C	D	E	SENSITROL VALVE	WT (Kg)
SAIFEE 6114-6	80	50	40	375	780	1813-02 C	86
SAIFEE 6114-7	25	65	50	400	850	1813-02 D	112
SAIFEE 6114-8A	150	65	65	44	1040	1813-02-D	153
SAIFEE 6114-8B	150	80	80	475	1213	1813-02 D	207
SAIFEE 6114-9	200	100	100	575	1430	1813-01	343
SAIFEE 6114-10	250	150	150	675	1590	1813-01	464

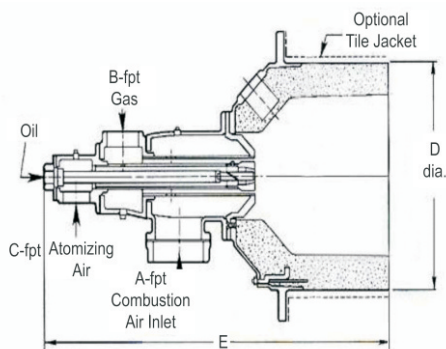

WEIGHT FOR COMPLETE TORCH AS SHOWN IN 6 LB

MODEL	MAIN AIR CAPACITIES (m ³ /hr)					SENSITROL VALVE	
	15 mbar	30	45	70	90	90	95
SAIFEE 6114-6	195	276	338	422	479	97	100
SAIFEE 6114-7	319	452	553	690	782	131	135
SAIFEE 6114-8A	555	786	962	1200	1316	209	215
SAIFEE 6114-8B	1349	1604	1776	1983	2249	360	370
SAIFEE 6114-9	1914	2707	3315	4135	4689	594	610
SAIFEE 6114-10	2858	4042	4951	6175	7002	939	965

SAIFEE ENGINEERING INDUSTRIES

T35A BIPLABI RASH BIHARI BASU ROAD KOLKATA 700001, INDIA TEL: +91 (33) 40245786 MOBILE: +91 9883038252
 EMAIL: saifeengind@gmail.com WEBSITE: www.saifeegroup.com WHATSAPP: +91 9883038252
 Information in this document is non-binding and subject to modification