

# GAS BURNERS

## SERIES 4114

# SAIFEE COMBUSTION EQUIPMENT

**4114 SAIFEE GAS BURNERS** are sealed-in-burners used for a wide variety of industrial applications. These burners are capable of efficient operation throughout a wide range of preheat air temperatures, and are equally stable on low temperature ovens as well as high temperature furnaces for reheating, forging, melting, drying etc.

The sealed mounting stops unwanted air from the atmosphere from entering the burner, which helps maintain furnace pressure, controlled atmosphere and better oil/gas ratio for improved product quality.

Saifee Gas burners are stable with 100% or more excess air. They can be turned down to much lower range but stability limits vary depending on burner size and furnace condition. For prolonged operations with low air pressure at temperatures above 850 °C, please specify an alloy burner nose.

Burners are suitable for preheated combustion air up to 350°C.

**JACKETED TILES** Saifee Gas burners are available with support jackets around the tiles for



applications where the tile is not supported by furnace refractory.

**IGNITION/ SUPERVISION:** Saifee pilot burner can be used for auto ignition. Pilot operation should be interrupted after few seconds. An UV cell will monitor pilot or main frame.

**TABLE 1: MAIN AIR CAPACITIES**

MODEL	COMBUSTION AIR CAPACITIES, m <sup>3</sup> /hr FOR kcal/ hr (MULTIPLY BY 880)					APPROXIMATE FLAME LENGTH (m)	
	mbar	15	30	45	70	90	MAIN AIR @ 70mbar
SAIFEE 4114-6		195	277	337	422	480	1.3
SAIFEE 4114-7		320	457	552	691	785	1.5
SAIFEE 4114-8A		555	791	964	1200	1360	2.4
SAIFEE 4514-8B		917	1308	1593	1982	2245	2.7
SAIFEE 4114-9		1917	2723	3340	4135	4690	4.8
SAIFEE 4114-10		2853	4107	4945	6174	7000	5.8

**TABLE 2: DIMENSION (MM)**

MODEL	A	B	C	D	APPROX WT (KG)
SAIFEE 4114-6	3"	2"	15"	14 <sup>15</sup> / <sub>16</sub> "	84
SAIFEE 4114-7	4"	2 1/2"	16"	16 <sup>3</sup> / <sub>4</sub> "	110
SAIFEE 4114-8A	6"	2 1/2"	17 <sup>3</sup> / <sub>4</sub> "	22 <sup>1</sup> / <sub>6</sub> "	150
SAIFEE 4114-8B	6"	3"	19"	25 <sup>15</sup> / <sub>16</sub> "	205
SAIFEE 4114-9	8"	4"	23"	31 <sup>3</sup> / <sub>4</sub> "	340
SAIFEE 4114-10	10"	6"	27 <sup>1</sup> / <sub>2</sub> "	35 <sup>1</sup> / <sub>6</sub> "	460

\*Air inlets of burners are in BSP thread

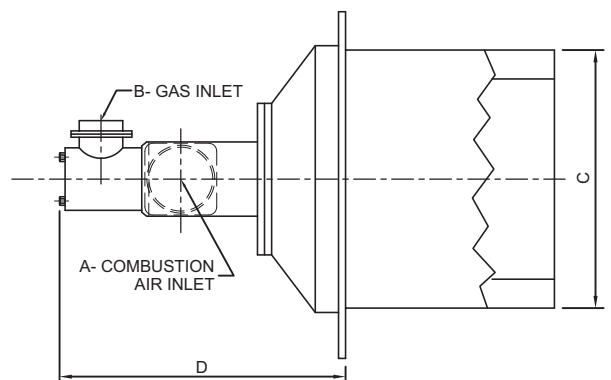

### SAIFEE ENGINEERING INDUSTRIES

135A BIPLABI RASH BIHARI BASU ROAD KOLKATA 700001, INDIA TEL: +91 (33) 40245786 MOBILE: +91 9883038252  
EMAIL: saifeeengind@gmail.com WEBSITE: www.saifeegroup.com WHATSAPP: +91 9883038252  
Information in this document is non-binding and subject to modification