



GLOBE OVERSEAS PVT. LTD.

TM.4524191

globe
100% INDIAN COMPANY
— WORLD LEADER IN LIFTING EQUIPMENT —
— 100% INDIAN COMPANY —

MATERIAL HANDLING EQUIPMENT

LET'S MAKE LIFTING SMARTER

Our Certificates

Our Facilities



Our Clientele

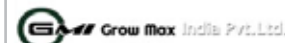

Monorail Travelling Trolley

Geared Type



Push Pull Type



Confirming to IS - 807 & 3177



• GEARED TYPE

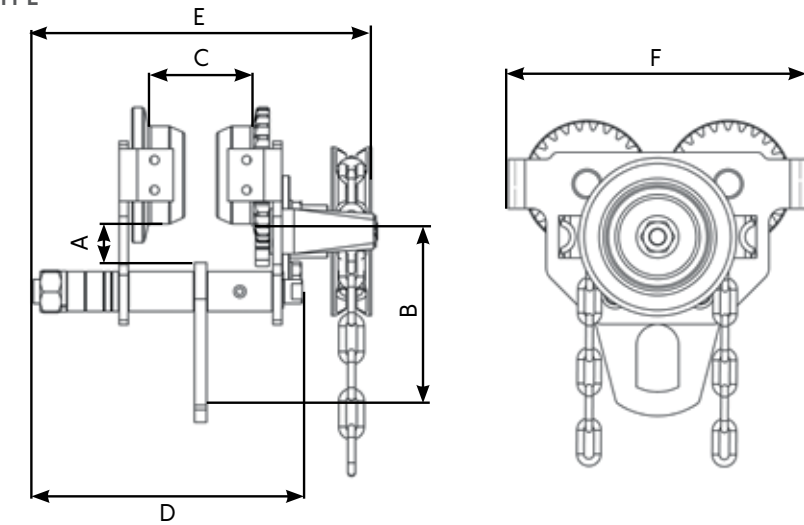

• PUSH PULL TYPE

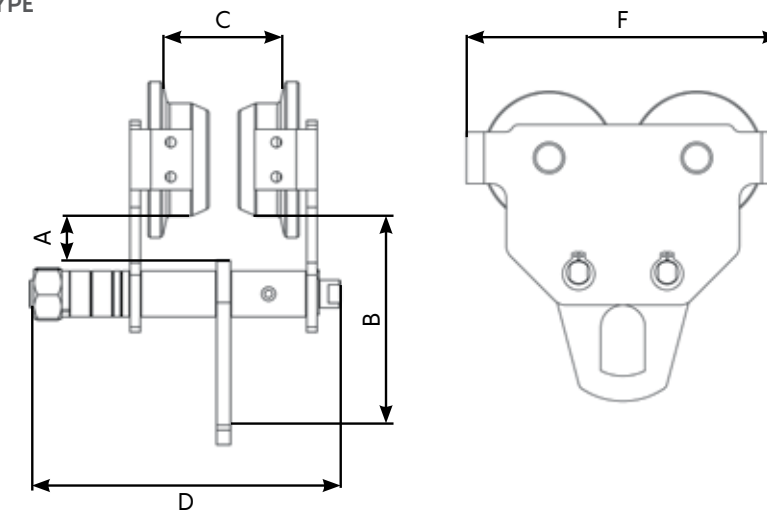

TECHNICAL SPECIFICATION

MONORAIL TRAVELLING TROLLEY										
		GEARED TYPE					PUSH PULL TYPE			
Model		GBT1	GBT2	GBT3	GBT5	GBT10	PPT1	PPT2	PPT3	PPT5
Capacity	Ton	1	2	3	5	10	1	2	3	5
Standard lifting height	Mtr	3	3	3	3	3	-	-	-	-
I-Beam recommended	mm	65-125	75-140	100-150	125-180	140-210	65-125	75-140	100-150	125-180
Dimension A	mm	24	27	31	30	28	24	27	31	30
Dimension B	mm	115	132	166	192	264	115	132	166	192
Dimension C	mm	60	80	104	130	147	60	80	104	130
Dimension D	mm	200	227	252	295	345	200	227	252	295
Dimension E	mm	258	284	308	350	407	-	-	-	-
Dimension F	mm	220	250	292	321	504	220	250	292	321
Packing measurement (LXWXH)	cm	28X25X23	30X28X25	32X32X28	36X35X30	36X35X30	53X43X41	25X23X17	29X25X20	32X30X30
Net weight with 3m lift	kg	13	19	27	39	94	9	14	22	33
Extra weight per meter of extra lift	kg	0.9	0.9	0.9	0.9	0.9	-	-	-	-
Hand Chain (φXpitch)	mm	5X22.5	5X22.5	5X22.5	5X22.5	5X22.5	-	-	-	-
Radius of curvature	mm	2000	2000	1500	1500	1500	2000	2000	1500	1500

Note :- Due to continuous development and improvement specification listed above may be changed without notice.

GLOBE OVERSEAS PVT. LTD.

Registered Office: B-9, DSIIIDC Engineering Complex,
Mangolpuri Industrial Area, Phase -1, New Delhi — 110083

Ph:- 011-46802215 / 9811628456 | Email id:- goplseas@gmail.com | Web:- www.globeoverseas.org

Works - 1: F-76, Sector — 2, DSIIIDC Industrial Area, Bawana, New Delhi — 110041

Works - 2: Kewat No. 646 Khasra No.178, Beri Kultana Road, Sampla, Distt. Rohtak, Haryana — 124501