

VMP 4 Cu.m

VMP



Tiltable Steering



Colour Display Controller (Optional)



Black and white Controller



Telematics

- Operator friendly
- Low maintenance cost
- 4X4 wheel drive 4 wheel steer

VMP 4000 Technical Specifications

Engine Make Model Operation Rated Power Rated RPM Emission Standard Total Displacement Cooling System	Kirloskar Oil Engines Limited 4R1040TA4 Turbo charged with air cooler 4 Cylinder & 110hp 2500 Bharat Stage -III (CEV) 4160 cc Combi Cooler-Water cooled	Vehicle Speed Low Speed 1 st / 2 nd gear High Speed 1 st / 2 nd gear	4.0 Km/h / 10.0 Km/h (Max Speed) 13.0 Km/h / 29.9 Km/h (Max Speed)
		Drives Steering Type Selection	Coordinate /2 Wheel/Crab (All 3 modes standard fitment)
Axle Axle Transmission Drive	Dana off-road CAT 2 axle with wet brakes Hydrostatic 4 wheel drive by renowned pump & motor	Electronic System Battery Starter Motor Alternator	12V, 150Ah 12V, 2.7kW 65A
		Electronic Weighing System Controller	Imported B/W, Color with language selection (Optional)
Tyre Wheel Base & Wheel Rim Tyre Size	2630 mm & 13x20 405/70-20 [16/70-20]	Overall Dimensions L x W x H	6560 x 2450 x 4130 mm
Mixing Unit Drum Capacity Drum Output Drum Rotation - Max Speed	5.3 Cu.m 4 Cu.m 21 rpm	Gradeability	25°
Chassis Chassis Type	Box Type	New Features Electronics & Mechanical ➤ Imported Controller ➤ Multi-featured cluster with CAN-BUS ready ➤ Curved glass cabin for better visibility ➤ Tracking system (GPS) on mobile and web ➤ Superior cooler for better fuel efficiency ➤ All mounting pins has option to rotate to avoid excessive wear on one side	
Weight Laden Weight Unladen Weight(Net Wight)	17 Tons 7.7 Tons		
Tank Capacities Fuel Tank Hydraulic Tank Water Tank	90 L 110 L 360 L x 2 = 720 L		
Bucket Volume Capacity	610 L		
Water System Flow Capacity	230 LPM @2000rpm		

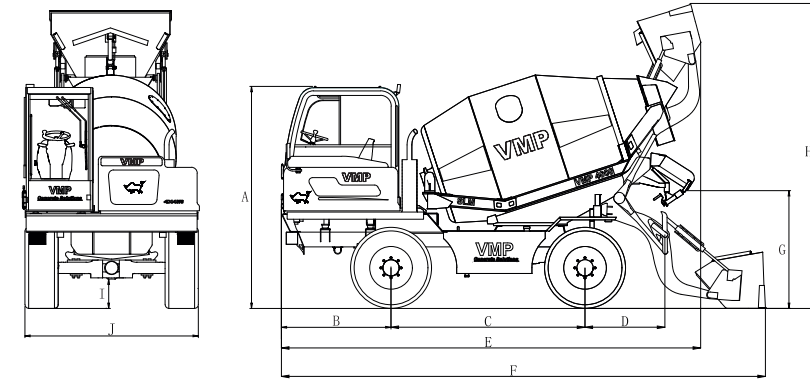

Loading & Mixing Performance

Dimension in mm	VMP 4 cu.m
A	3010
B	1490
C	2630
D	1087
E	5680
F	6560
G	1597
H	4130
I	385
J	2450



****All dimensions, shapes, weight & specification may have allowed variance. The information contained in this leaflet is for illustration purpose only. VMP reserves the right to change without prior notice.**

**VMP Concrete Equipments Pvt Ltd, 13/54, Trichy Road, Chinthamanipur, Coimbatore - 641 103, India.
 Call : +91 77085 22022 | visit : www.vmpequipments.com | email : mktg@vmpequipments.com**