

# Accordion Fire Curtains

*30 years of experience in supplying and installing fire and smoke curtains.*

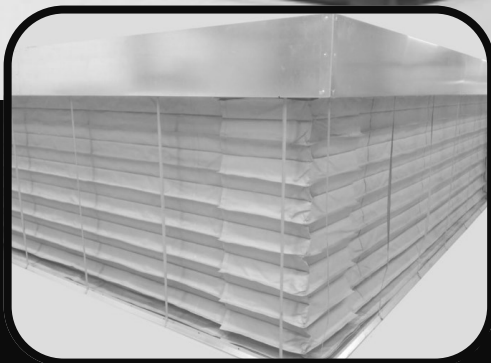

**NO CORNER POST NEEDED!**  
Create continuous shapes even around corners without guide rails! Turn over to learn more.



## Turn corners and achieve fire protection for complex shapes without the need for posts in between!

*We provide a top of the line fire protection system that doesn't compromise the design aesthetic you want to achieve. Automatic accordion fire curtains protect against the threat of fire, smoke and hot gases in the event of a fire, and are a lightweight and compact solution to traditional fire rated roller shutters. These automatic barriers **save lives and protect property** in addition to enabling open air designs where otherwise a permanent fire rated partition would be required.*





#### STORE AWAY

Without our accordion fire curtain, providing this atrium with fire protection would mean having permanent posts (guide rails) at the corners. This would have limited the architects ability to design open spaces and unacceptably spoil the aesthetic.



#### PARTIAL DEPLOYMENT

Watch as the curtains descend neatly and simultaneously under the power of gravity (read more gravity fail safe later). The bottom tray can be powder coated white to suit the ceiling for a seamless look when stored away.



#### FULL DEPLOYMENT

Complete fire compartmentation is effected for 3 hours upon full deployment. The curtain design requires minimal headroom starting at 280mm. **DON'T LET FIRE PROTECTION DICTATE YOUR DESIGN. Specify the Accordion system.**

## FEATURES

- Fire rated for up to 3 hours (E180) @ 1000 degrees.
- No side posts needed. Design and fire protect almost any shape.
- Compact headroom requirement starting from 280mm (high)
- Intelligent controls ensure straight deployment.
- True gravity fail safe system; the curtain will descend to operational position even under complete power failure.
- "2 in 1" fire and smoke containment
- 70 % radiant heat reduction when compared with fire shutters.
- Neat and attractive ceiling interfaces.



High tensile weave with interwoven stainless steel. The fabric weight is approximately 660 g/m<sup>2</sup>.

#### MATERIAL

Woven glass fibres, reinforced with stainless steel wires with a silver polyurethane coating for flexibility and lower radiated heat; sewn with stainless steel thread.

# HOW DOES A FIRE CURTAIN OPERATE?

## How are the curtains stored in normal situations?

Under normal conditions, the curtain remains retracted in the compact head box installed above the false ceiling. It is held in place by an extra low voltage supply with the bottom tray resting against the underside of the headbox or below the box depending on the application.

## How are the curtains activated?

- 1) Via the fire alarm signal
- 2) Via other detection systems like heat / smoke detectors
- 3) During a power outage (a back up battery will hold the curtain in position for 60 minutes before it descends)
- 4) Turning the test key switch for regular safety testing

The group control panel (GCP) removes the power supply to the motor control circuit (MCC) and the extra low voltage to the motor is suspended. Since the brake has been released, the weight of the bottom tray pulls the curtain down to its operational position. When the signal is reset, the GCP restores power to the MCC which retracts the curtain up and back to its normal position.

## CONTROLLED GRAVITY FAIL SAFE DESCENT

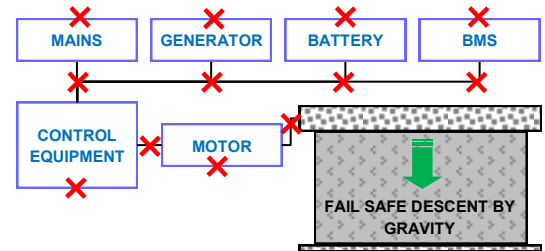

Our Gravity Fail Safe ensures that under any scenario, the curtain will descend by gravity. The curtain does not fall like a guillotine but descends at a controlled and constant. This is because the voltage generated by the rotating motor feeds the electronic speed monitoring system which ensures that the speed is within safe limits as set by International Standards.

# BASIC CONSTRUCTION & FIXING

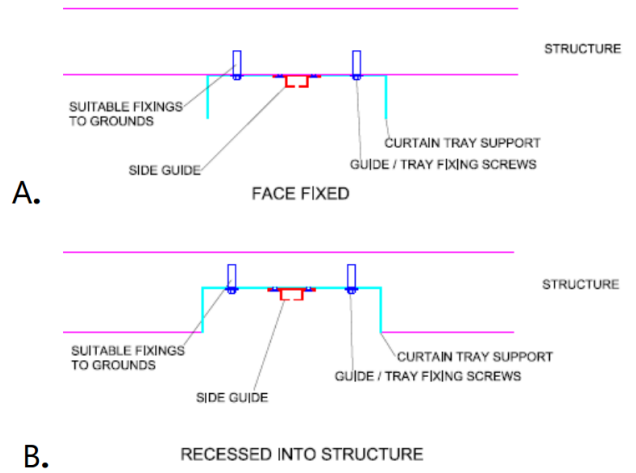
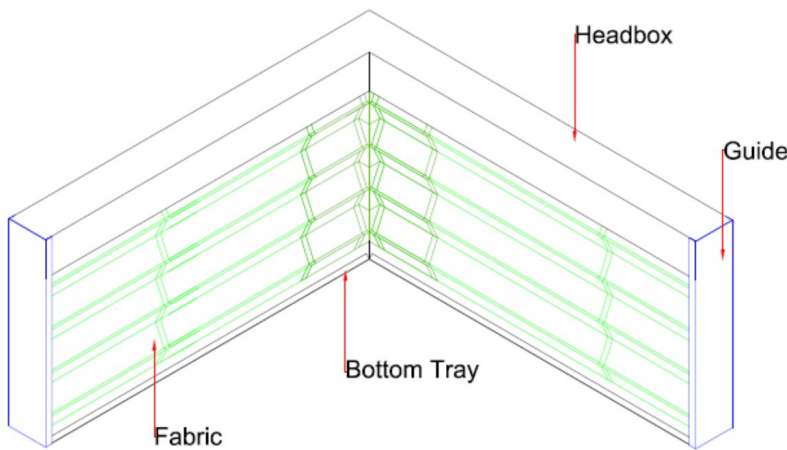

# STANDARD HEAD BOX & SIZES

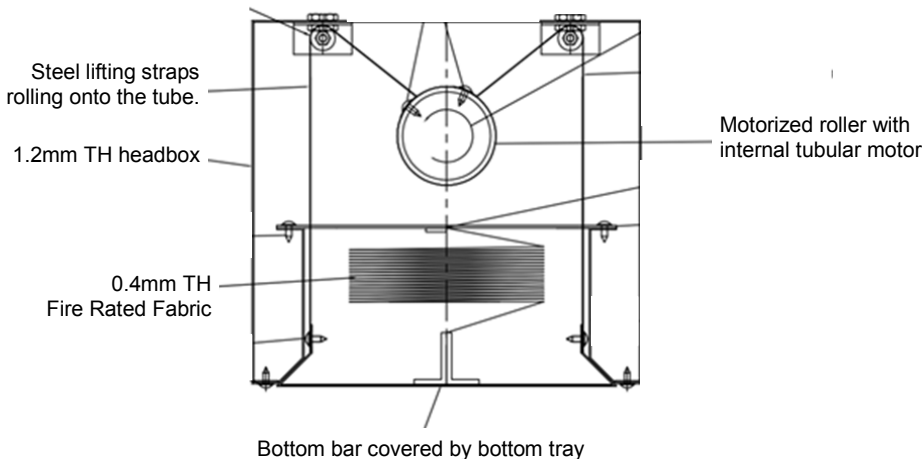

sizes are W x H

CURTAIN DROP	BOX SIZE
Up to 3m	300mm x 280mm
From 3m to 6m	300mm x 400mm



## SPECIFICATION

The **Automatic Accordion Fire Curtain** creates a fire rated compartment using innovative construction methods, in such a way that eliminates the need for posts when turning corners. It consists of a reinforced fire rated fabric that is pleated, stitched and housed within a steel head-box tucked away out of sight. When a fire compartment is required to be created, the fabric and bottom tray drop from the ceiling to the floor in a controlled manner, effecting a fire rated barrier. Powered by an internal, electric, tubular geared motor, all working parts are totally enclosed and protected within the box with required access panels for maintenance. *The complete system is tested for controlled gravity fail-safe on total power failure which is not reliant on secondary power supply.*

### Certifications & Documentation

Ferco's Fire Curtain has full testing and certification to UL standards and will comply with local civil defense requirements.

### Construction

A dia 76mm roller (4mm thick) complete with internal tubular motor, folded curtain, bottom tray and all associated fittings, is fully enclosed within a 1.2mm galvanized mild steel box.

Stainless steel lifting straps shall be screwed to the roller on one end and the bottom tray at the other. These straps shall be configured and fixed in such a manner that descent of the bottom tray shall be level at all times.

One end of the folded and stitched fabric shall be affixed to the headbox and the other end to the bottom tray, in such a manner that upon controlled deployment / retraction of the bottom tray, the fabric shall retain its designed shape.

Where the system is designed to be an open system, side guides will be provided to interface with the building structure. Where designed to be an enclosed system, side guides shall not be required.

### Operation

Under normal conditions the curtain is retracted in the head box and is held in position by an extra low voltage supply from the semi conductor regulator in the motor control circuit (MCC). The bottom tray will be resting against the underside of the box. In the event of a fire condition or operation of the test key switch, the group control panel removes the power to the MCC's and the extra low voltage supply to the motor is

isolated. The curtain descends by using the weight of the bottom bar and deploys the fabric at a controlled rate.

The Fire Curtain operates with mains power and is also operable with emergency power source. If both mains and emergency power fail, the system will descend, under gravity with a controlled rate of descent after a time delay of 60 minutes, as a safety feature to avoid dangerous guillotine/fall descent. The system is operated by alarm / control signal and / or specified fail-safe functions

### Controls

Ferco's Fire Curtain operates through Group Control Panel (GCP) located adjacent to the units with the Main Fire Alarm Panel (MFAP), Motor Control Panel/s (MCP) located adjacent to motors, have appropriate access panels. The system is fully protected and failsafe to avoid fire rated cabling. In case of temporary power interruption, curtain will be in raised position for a time duration of 60 minutes, after which the curtain will descend if power is not returned. GCP has audio and visual power failure warning system as an optional which is operable with both mains and emergency power.

### Fabric

Woven with glass fibers with reinforced stainless steel wires with a silver polyurethane; The fabric achieves 180 minute fire resistance at 1000 C according to the time temperature curve of BS476 Part 20 1987, and weighs about 700 grams / m<sup>2</sup>. Fabric meets the requirements for Fire Propagation of BS476 Part 6 1989 and has Nil spread of Flame, achieving Class 1 according to BS476 part 7 1987.

### M & E Requirements

Voltage free, normally closed Fire Alarm signal, 230V, single phase, 50Hz, 13A power supply

### Optional

- >Audio / visual alarms
- >Monitoring the fire curtain through a BMS system or remotely with dedicated monitors.
- >Powder-coated bottom bar and guide rails.
- >Emergency retract button
- >Two stage descent ./ delayed descent
- >Obstruction sensor



**ferco**  
SHUTTERS & SEATING

24 HOUR SERVICE & MAINTENANCE  
CALL US AT +65 9001 7059

### SINGAPORE

120 Hillview Avenue  
#02-04 Kewalram Hillview,  
Singapore 669594

Tel: +65 6760 8383  
Fax: +65 6760 7503  
[sales@fercoshutters.com](mailto:sales@fercoshutters.com)

### DUBAI

Plot 247-125 Shed 1 & 2  
Al Qusais, Industrial Area 4  
P.O. Box 233962 Dubai UAE

Tel: +971 (04) 258 6433  
Fax: +971 (04) 258 6533  
[enquiryUAE@fercoshutters.com](mailto:enquiryUAE@fercoshutters.com)

### ABU DHABI

M-04 Abu Dhabi Finance Bldg  
Tourist Club Area  
Box 113651, Abu Dhabi UAE

Tel: +971 (02) 679 7609  
Fax: +971 (02) 679 7608  
[enquiryUAE@fercoshutters.com](mailto:enquiryUAE@fercoshutters.com)