

Precision Universal Joint



# PRECISION UNIVERSAL JOINT

## Sit universal joints with plain or needle roller bearings Type “E” - “H” (DIN 808)

Of this series both single and double joints are available. Types E are with sliding bushes while type H has needle roller bearings.

Joints with plain bearings are available in 2 versions:

- types E to DIN 808;
- types EB to DIN 808/7551

Joints with roller bearings are available in 2 versions:

- types H to DIN 808;
- types HB to DIN 808/7551

They all consist of a star wheel core and 2 half joints with fork ends. Between the pins of the star wheel and the holes of the forks, 4 wear-resistant sliding bushes (for type E) or roller bearings (type H - high speed) are fitted in.

The 4 bushes have holes for lubrication and each one contains a grease reserve.

The hermetic structure prevents lubricant losses and impurity entry.

Neither lubrication or maintenance is required for type H (high speed joints with roller bearings) as their bearings are lubricated for life.

Joints with plain bearings - type E - are for middle-low speeds and where there are shock loads. For high speeds and relatively low torques types with roller bearings (H) are recommended.

Both versions offer high efficiency, silent running, low friction, coefficient at competitive prices.

All rubbing surfaces are hardened and ground.

Maximum working angle is 45° for single joints and 90° for double joints.

Maximum speed is 1.000 rpm for type E, while type H can exceed 4.000 rpm.

All versions are also supplied in telescopic versions.

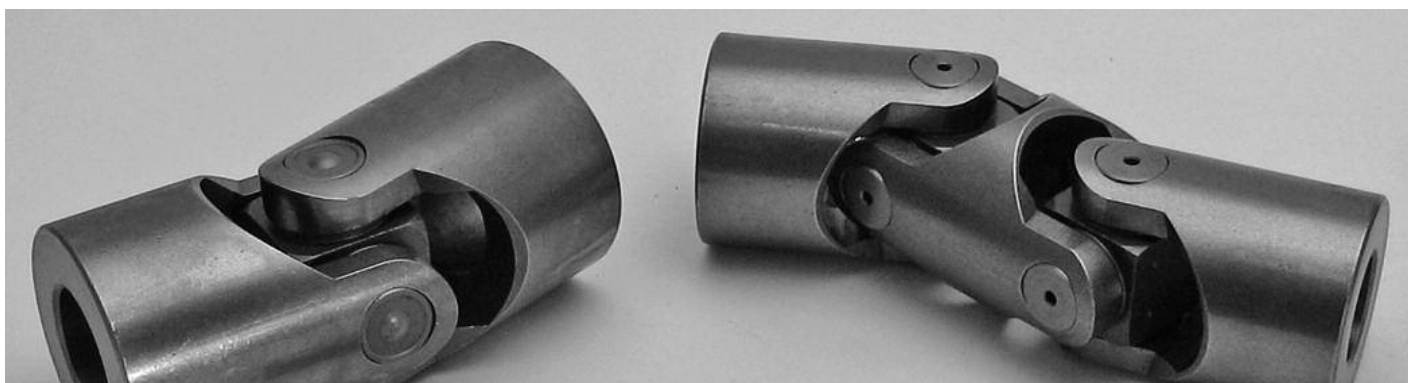

# Precision joint Series "E" (DIN 808)

- Wear resistant sliding bushes from cemented and hardened steel.
- Strong, precise, and versatile; wide application field.
- Max. angle: 45° type "E", 90° type "ED". max. speed 1.000 rpm.
- Special executions upon request.

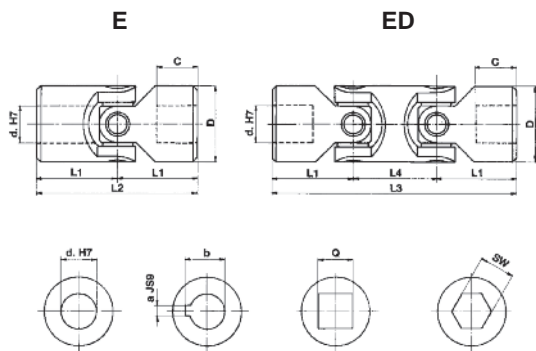

Type	Type	d [mm]	D [mm]	L2 [mm]	L1 [mm]	C [mm]	L4 [mm]	L3 [mm]	a [mm]	b [mm]	Q [mm]	SW [mm]	Weight [kg]	
													E	ED
GU01E	GU01ED	6	16	34	17	8	22	56	2	7	6	6	0,05	0,08
GU02E	GU02ED	8	16	40	20	11	22	62	2	9	8	8	0,05	0,08
GU03E	GU03ED	10	22	48	24	12	26	74	3	11,4	10	10	0,10	0,15
GU04E	GU04ED	12	25	56	28	13	30	86	4	13,8	12	12	0,16	0,25
GU05E	GU05ED	14	28	60	30	14	36	96	5	16,3	14	14	0,20	0,40
GU1E	GU1ED	16	32	68	34	16	36	104	5	18,3	16	16	0,30	0,45
GU2E	GU2ED	18	36	74	37	17	40	114	6	20,8	18	18	0,45	0,70
GU3E	GU3ED	20	42	82	41	18	46	128	6	22,8	20	20	0,60	1,00
GU4E	GU4ED	22	45	95	47,5	22	50	145	6	24,8	22	22	0,95	1,55
GU5E	GU5ED	25	50	108	54	26	55	163	8	28,3	25	25	1,20	2,00
GU6E	GU6ED	30	58	122	61	29	68	190	8	33,3	30	30	1,85	2,90
GU6E1	GU6ED1	32	58	130	65	33	68	198	10	35,3	30	30	2,00	3,00
GU7E	GU7ED	35	70	140	70	35	72	212	10	38,3	••	••	3,15	4,75
GU8E	GU8ED	40	80	160	80	39	85	245	12	43,3	••	••	4,60	7,20
GU9E	GU9ED	50	95	190	95	46	100	290	14	53,8	••	••	7,60	12,00

DIN 808

Type	Type	d [mm]	D [mm]	L2 [mm]	L1 [mm]	C [mm]	L4 [mm]	L3 [mm]	a [mm]	b [mm]	Q [mm]	SW [mm]	Weight [kg]	
													E	ED
GU03EB	GU03EBD	10	16	52	26	15	22	74	3	11,4	8	8	0,05	0,08
GU04EB	GU04EBD	12	22	62	31	18	26	88	4	13,8	10	10	0,12	0,20
GU1EB	GU1EBD	16	25	74	37	21	30	104	5	18,3	12	12	0,20	0,30
GU3EB	GU3EBD	20	32	86	43	24	38	124	6	22,8	16	16	0,35	0,50
GU5EB	GU5EBD	25	42	108	54	31	48	156	8	28,3	20	20	0,80	1,20
GU6EB	GU6EBD	30	50	132	66	38	56	188	8	33,3	25	25	1,20	1,70
GU8EB	GU8EBD	40	70	166	83	47	72	238	12	43,3	••	••	2,90	4,30

DIN 808/7551

•• = upon request

# Extensible transmissions

## Series "E" (DIN 808)

- Joints series "E" type "EA" with wear resistant sliding bushes.
- Min. and max. length upon request:

$$L_{MIN} \geq \frac{L_{MAX} + 2 L_2 + B}{2}$$

$$Corso X \leq \frac{L_{MAX} - 2 L_2 - B}{2}$$

- Special execution upon request

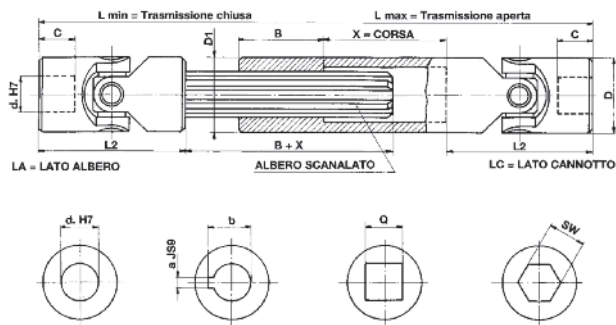

Type	d [mm]	D [mm]	L2 [mm]	C [mm]	Lmin [mm]	Lmax [mm]	X [mm]	B [mm]	a [mm]	b [mm]	Q [mm]	SW [mm]	Shaft profile	D1 [mm]		
GU01EA	6	16	34	8	upon request			25	2	7	6	6	SW 8	16		
GU02EA	8	16	40	11				25	2	9	8	8	8	8	SW 8	16
GU03EA	10	22	48	12				30	3	11,4	10	10	10	10	11 x 14 Z6	22
GU04EA	12	25	56	13				40	4	13,8	12	12	12	12	13 x 16 Z6	26
GU05EA	14	28	60	14				40	5	16,3	14	14	14	14	13 x 16 Z6	29
GU1EA	16	32	68	16				40	5	18,3	16	16	16	16	16 x 20 Z6	32
GU2EA	18	36	74	17				40	6	20,8	18	18	18	18	18 x 22 Z6	37
GU3EA	20	42	82	18				45	6	22,8	20	20	20	20	21 x 25 Z6	42
GU4EA	22	45	95	22				45	6	24,8	22	22	22	22	23 x 28 Z6	47
GU5EA	25	50	108	26				45	8	28,3	25	25	25	25	26 x 32 Z6	52
GU6EA	30	58	122	29				50	8	33,3	30	30	30	30	32 x 38 Z8	58
GU7EA	35	70	140	35				70	10	38,3	••	••	••	••	36 x 42 Z8	70
GU8EA	40	80	160	39				80	12	43,3	••	••	••	••	42 x 48 Z8	80
GU9EA	50	95	190	46				90	14	53,8	••	••	••	••	46 x 54 Z8	95

Type	d [mm]	D [mm]	L2 [mm]	C [mm]	Lmin [mm]	Lmax [mm]	X [mm]	B [mm]	a [mm]	b [mm]	Q [mm]	SW [mm]	Shaft profile	D1 [mm]		
GU03EBA	10	16	52	14	upon request			25	3	11,4	8	8	SW 8	16		
GU04EBA	12	22	62	18				30	4	13,8	10	10	10	10	11 x 14 Z6	22
GU1EBA	16	25	74	21				40	5	18,3	12	12	12	12	13 x 16 Z6	26
GU3EBA	20	32	86	24				40	6	22,8	16	16	16	16	16 x 20 Z6	32
GU5EBA	25	42	108	31				45	8	28,3	20	20	20	20	21 x 25 Z6	42
GU6EBA	30	50	132	38				45	8	33,3	25	25	25	25	26 x 32 Z6	52
GU8EBA	40	70	166	47				75	12	43,3	••	••	••	••	36 x 42 Z8	70

•• = upon request

# High speed precision joints with needle roller bearings

## Series “H” (DIN 808)

- Roller bearings lubricated for life. No maintenance required.
- Precise and versatile, silent and smooth running; wide application field.
- Max. angle: 45° type “H”, 90° type “HD”, max. speed 4.000 rpm.
- Special executions upon request.

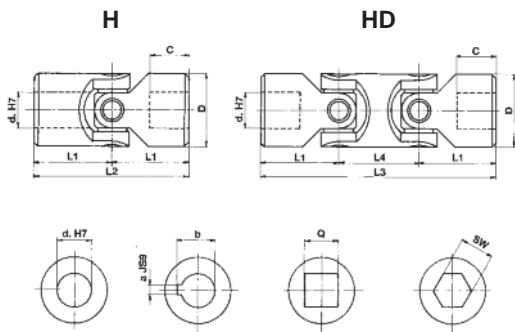

Type	Type	d [mm]	D [mm]	L2 [mm]	L1 [mm]	C [mm]	L4 [mm]	L3 [mm]	a [mm]	b [mm]	Q [mm]	SW [mm]	Weight [kg]	
													H	HD
GU03H	GU03HD	10	22	48	24	12	26	74	3	11,4	10	10	0,10	0,15
GU04H	GU04HD	12	25	56	28	13	30	86	4	13,8	12	12	0,16	0,25
GU05H	GU05HD	14	28	60	30	14	36	96	5	16,3	14	14	0,20	0,40
GU1H	GU1HD	16	32	68	34	16	36	104	5	18,3	16	16	0,30	0,45
GU2H	GU2HD	18	36	74	37	17	40	114	6	20,8	18	18	0,45	0,70
GU3H	GU3HD	20	42	82	41	18	46	128	6	22,8	20	20	0,60	1,00
GU4H	GU4HD	22	45	95	47,5	22	50	145	6	24,8	22	22	0,95	1,55
GU5H	GU5HD	25	50	108	54	26	55	163	8	28,3	25	25	1,20	2,00
GU6H	GU6HD	30	58	122	61	29	68	190	8	33,3	30	30	1,85	2,90
GU6H1	GU6HD1	32	58	130	65	33	68	198	10	35,3	30	30	2,00	3,00
GU7H	GU7HD	35	70	140	70	35	72	212	10	38,3	••	••	3,15	4,75
GU8H	GU8HD	40	80	160	80	39	85	245	12	43,3	••	••	4,60	7,20
GU9H	GU9HD	50	95	190	95	46	100	290	14	53,8	••	••	7,60	12,00

DIN 808

Type	Type	d [mm]	D [mm]	L2 [mm]	L1 [mm]	C [mm]	L4 [mm]	L3 [mm]	a [mm]	b [mm]	Q [mm]	SW [mm]	Weight [kg]	
													HB	HBD
GU04HB	GU04HBD	12	22	62	31	18	26	88	4	13,8	10	10	0,12	0,20
GU1HB	GU1HBD	16	25	74	37	21	30	104	5	18,3	12	12	0,20	0,30
GU3HB	GU3HBD	20	32	86	43	24	38	124	6	22,8	16	16	0,35	0,50
GU5HB	GU5HBD	25	42	108	54	31	48	156	8	28,3	20	20	0,80	1,20
GU6HB	GU6HBD	30	50	132	66	38	56	188	8	33,3	25	25	1,20	1,70
GU8HB	GU8HBD	40	70	166	83	47	72	238	12	43,3	••	••	2,90	4,30

DIN 808/7551

•• = upon request

# Extensible transmissions high speed

## Series "H" (DIN 808)

- High speed joints series "H", type "HA", with needle roller bearings.
- Min. and max. length upon request: rpm.

$$L_{MIN} \geq \frac{L_{MAX} + 2 L_2 + B}{2} \qquad \text{Corsa } X \leq \frac{L_{MAX} - 2 L_2 - B}{2}$$

- Special executions on request.

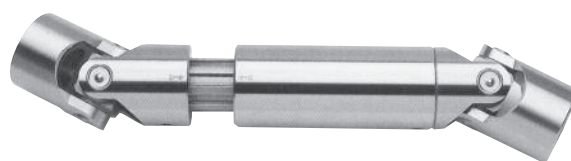
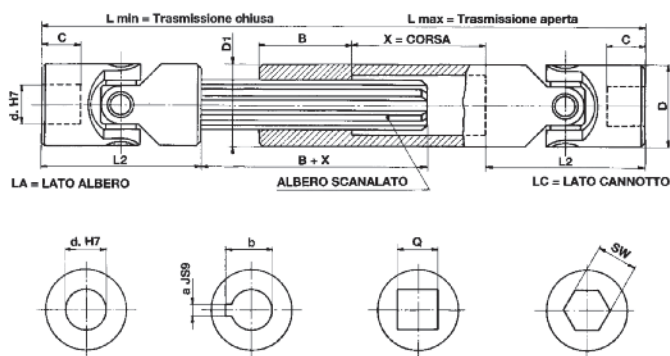

Typo	d [mm]	D [mm]	L2 [mm]	C [mm]	Lmin [mm]	Lmax [mm]	X [mm]	B [mm]	a [mm]	b [mm]	Q [mm]	SW [mm]	Albero	D1 [mm]			
GU03HA	10	22	48	12	upon request			30	3	11,4	10	10	11 x 14 Z6	22			
GU04HA	12	25	56	13				40	4	13,8	12	12	13 x 16 Z6	12	13 x 16 Z6	26	
GU05HA	14	28	60	14				40	5	16,3	14	14	13 x 16 Z6	14	13 x 16 Z6	29	
GU1HA	16	32	68	16				40	5	18,3	16	16	16 x 20 Z6	16	16 x 20 Z6	32	
GU2HA	18	36	74	17				40	6	20,8	18	18	18 x 22 Z6	18	18 x 22 Z6	37	
GU3HA	20	42	82	18				45	6	22,8	20	20	21 x 25 Z6	20	21 x 25 Z6	42	
GU4HA	22	45	95	22				45	6	24,8	22	22	23 x 28 Z6	22	23 x 28 Z6	47	
GU5HA	25	50	108	26				45	8	28,3	25	25	26 x 32 Z6	25	26 x 32 Z6	52	
GU6HA	30	58	122	29				50	8	33,3	30	30	32 x 38 Z8	30	32 x 38 Z8	58	
GU7HA	35	70	140	35				70	10	38,3	••	••	36 x 42 Z8	••	••	36 x 42 Z8	70
GU8HA	40	80	160	40				80	12	43,3	••	••	42 x 48 Z8	••	••	42 x 48 Z8	80
GU9HA	50	95	190	50				90	14	53,8	••	••	46 x 54 Z8	••	••	46 x 54 Z8	95

Typo	d [mm]	D [mm]	L2 [mm]	C [mm]	Lmin [mm]	Lmax [mm]	X [mm]	B [mm]	a [mm]	b [mm]	Q [mm]	SW [mm]	Albero	D1 [mm]		
GU04HBA	12	22	62	18	upon request			30	4	13,8	10	10	11 x 14 Z6	22		
GU1HBA	16	25	74	21				40	5	18,3	12	12	13 x 16 Z6	12	13 x 16 Z6	26
GU3HBA	20	32	86	24				40	6	22,8	16	16	16 x 20 Z6	16	16 x 20 Z6	32
GU5HBA	25	42	108	31				45	8	28,3	20	20	21 x 25 Z6	20	21 x 25 Z6	42
GU6HBA	30	50	132	38				45	8	33,3	25	25	26 x 32 Z6	25	26 x 32 Z6	52
GU8HBA	40	70	166	47				70	12	43,3	••	••	36 x 42 Z8	••	••	36 x 42 Z8

•• = upon request

## Precision joints Series “ER” (sliding bushes) - “HR” (needle roller bearings)

- Type “ER”: max. speed 1.000 rpm.
- Type “HR”: max. speed 4.000 rpm.
- Max. angle 45°.

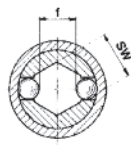
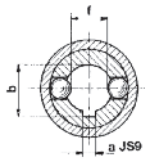
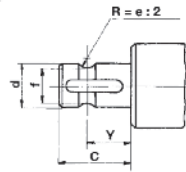
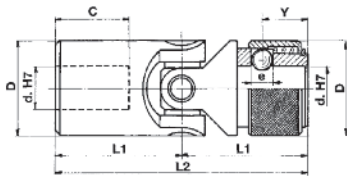

ER



HR

Type	Type	d [mm]	D [mm]	L2 [mm]	L1 [mm]	C [mm]	Y [mm]	e [mm]	f [mm]	a [mm]	b [mm]	SW [mm]
GU02ER	-	8	16	52	26	14	9,5	3,5	6,3	2	9	8
GU03ER	GU03HR	10	22	62	31	17	11,5	4	8,7	3	11	10
GU04ER	GU04HR	12	25	74	37	21	13,5	4	11	4	13,3	12
GU05ER	GU05HR	14	25	74	37	21	13,5	4	13	5	15,3	14
GU1ER	GU1HR	16	32	86	43	24	14	6,35	14,8	5	17,3	16
GU2ER	GU2HR	18	36	96	48	28	19	8	16	6	19,8	18
GU3ER	GU3HR	20	42	108	54	31	19	8	18	6	22,8	20
GU4ER	GU4HR	22	45	120	60	34	20,5	10	20	6	24,8	22
GU5ER	GU5HR	25	50	132	66	38	20,5	10	23	8	28,3	25
GU6ER	GU6HR	30	58	166	83	49	25	10	28	8	33,3	30

# Stainless steel joints

## Series "X" (DIN 808)

- Max. angle: 45° type "X", 90° type "XD".
- Special executions upon request.

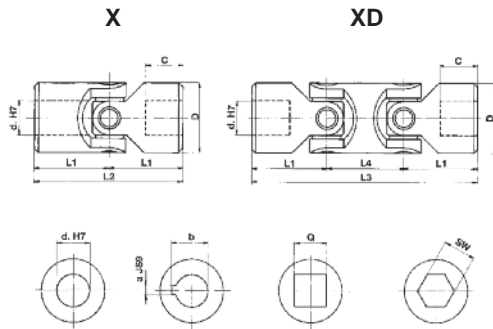

Type	Type	d [mm]	D [mm]	L2 [mm]	L1 [mm]	C [mm]	L4 [mm]	L3 [mm]	a* [mm]	b* [mm]	Q* [mm]	SW* [mm]	Weight [kg]	
													X	XD
GU01X	GU01XD	6	16	34	17	8	22	56	2	7	6	6	0,05	0,08
GU02X	GU02XD	8	16	40	20	11	22	62	2	9	8	8	0,05	0,08
GU03X	GU03XD	10	22	48	24	12	26	74	3	11,4	10	10	0,10	0,15
GU04X	GU04XD	12	25	56	28	13	30	86	4	13,8	12	12	0,16	0,25
GU1X	GU1XD	16	32	68	34	16	36	104	5	18,3	16	16	0,30	0,45
GU3X	GU3XD	20	42	82	41	18	46	128	6	22,8	20	20	0,60	1,00
GU5X	GU5XD	25	50	108	54	26	55	163	8	28,3	25	25	1,20	2,00
GU6X	GU6XD	30	58	122	61	29	68	190	8	33,3	30	30	1,85	2,90

\* = check availability



## Protection muffs Series "M"

- Special neoprene rubber.
- Resistant to acids, oils, grease, dust and moisture.
- Filled with grease to ensure constant lubrication.

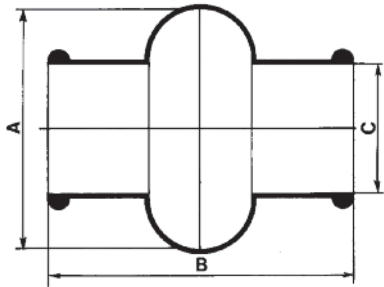

Type	A [mm]	B [mm]	C [mm]	Joint external diameter D [mm]
GU01M	28	34	15	16
GU02M	32	40	16,5	18
GU03M	40	45	20,5	22
GU04M	48	50	24,5	25/26
GU05M	52	56	27,5	28/29
GU1M	56	65	30,5	32
GU2M	66	72	35,5	36/37
GU3M	75	82	40	42
GU4M	84	95	45	45/47
GU5M	92	108	50	50/52
GU6M	100	122	56	58

## Selecting criteria

Matching one single joint with two shafts (of which the driving one is rotating at a constant speed), it forms an angle which causes a periodic variation of the driven shaft, exactly four fluctuations per revolution.

The difference between the maximum and the minimum speed of the driven shaft depends on the angle formed by the two shafts. The difference grows when increasing of the angle  $\alpha$ .

To have a homokinetic transmission, you have to fit either two opposite single joints (paying attention that the two central yokes lie on the same plane and the angles are equal) or a double joint. The irregularity caused by the former articulation is cancelled by the latter. The overall length resulting from the coupling of the two single joints is even more reduced using a double joint. In other words, the double joint is to be considered the shortest homokinetic transmission.

For low speed applications (max 1.000 rpm) joint with plain bearings (rubbing bearings) are suggested: types E/EB. They are able to support shock loads, drive reserves, irregular runnings and relatively high torques. The working angles must be reduced in operation between 500 and 1.000 rpm.

For high rotation speeds, relatively low torques or wide angles, joints with needle roller bearings (type V - H) are preferred. They can reach 5.000 rpm always relating to the angle.

### How to read diagrams

The joint capacity to transmit a regular torque at a constant load with no shocks for a more or less long period, mainly depends on the number of revolutions per minute and the inclination angle  $\alpha$  of the two axes.

The following diagrams are based upon the criteria below. Each curve corresponds to the joint size (outside diameter D) and represents the torque that the joint can transmit depending upon speed and working angle  $\alpha$ .

The diagrams can be directly read if angle  $\alpha$  is 10°; for wider angles, torques are reduced, therefore the values are to be corrected using correction factors (F) relating to the angle shown in the table.

### Note:

Diagrams' values are merely indicative. Each application has its own particular motion characteristics, such as: shock loads, motion reversals, connected masses, type of starting, presence of elastic joints, stops and starts, etc. We, therefore, suggest calling our technical department.

# Diagram for joints Series "E"

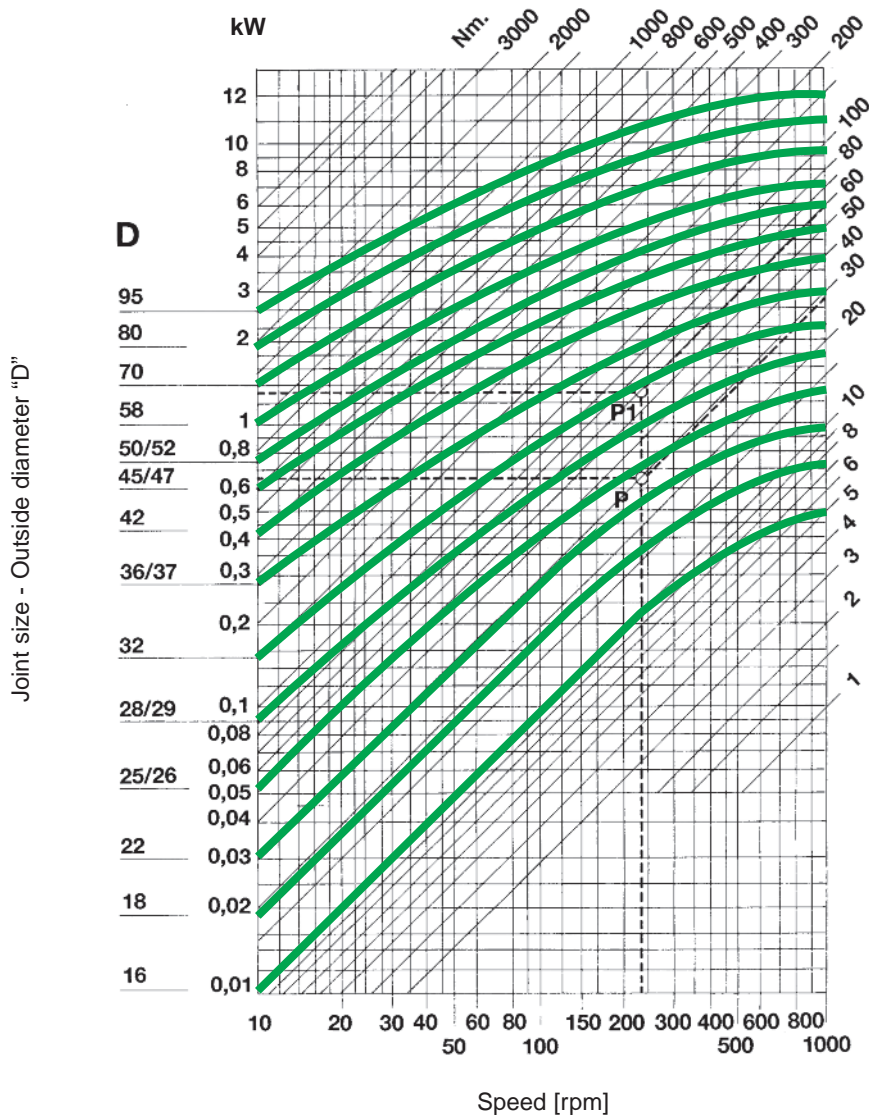

Torque  $M_T$  in [Nm]

WORKING ANGLE "α"	5°	10°	15°	20°	25°	30°	35°	40°	45°
CORRECTION FACTOR "F"	1,25	1,00	0,80	0,65	0,55	0,45	0,38	0,30	0,25

### Example

- Power: 0,65 kW
- rpm: 230 min<sup>-1</sup>
- With working angle  $\alpha = 10^\circ$ , Factor  $F = 1,00$  ( 0,65 kW : 1,00 = 0,65 kW) we get point P and Torque  $M_T = 27$  Nm corresponding to joint size  $D = 25/26$  mm (type 04E, 1EB)
- With working angle  $\alpha = 30^\circ$ , Factor  $F = 0,45$  (0,65 kW : 0,45 = 1,44 kW) we get point P1 and Torque  $M_T = 60$  Nm corresponding to joint size  $D = 32$  mm (type 1E, 3EB).

Consider that:

$$M_T = 9.550 \times \frac{\text{Power [kW]}}{\text{rpm [min}^{-1}\text{]}} \quad [\text{Nm}]$$

$$M_T = 7.020 \times \frac{\text{Power [CV]}}{\text{rpm [min}^{-1}\text{]}} \quad [\text{Nm}]$$

## Diagram for joints Series "H" - High Speed

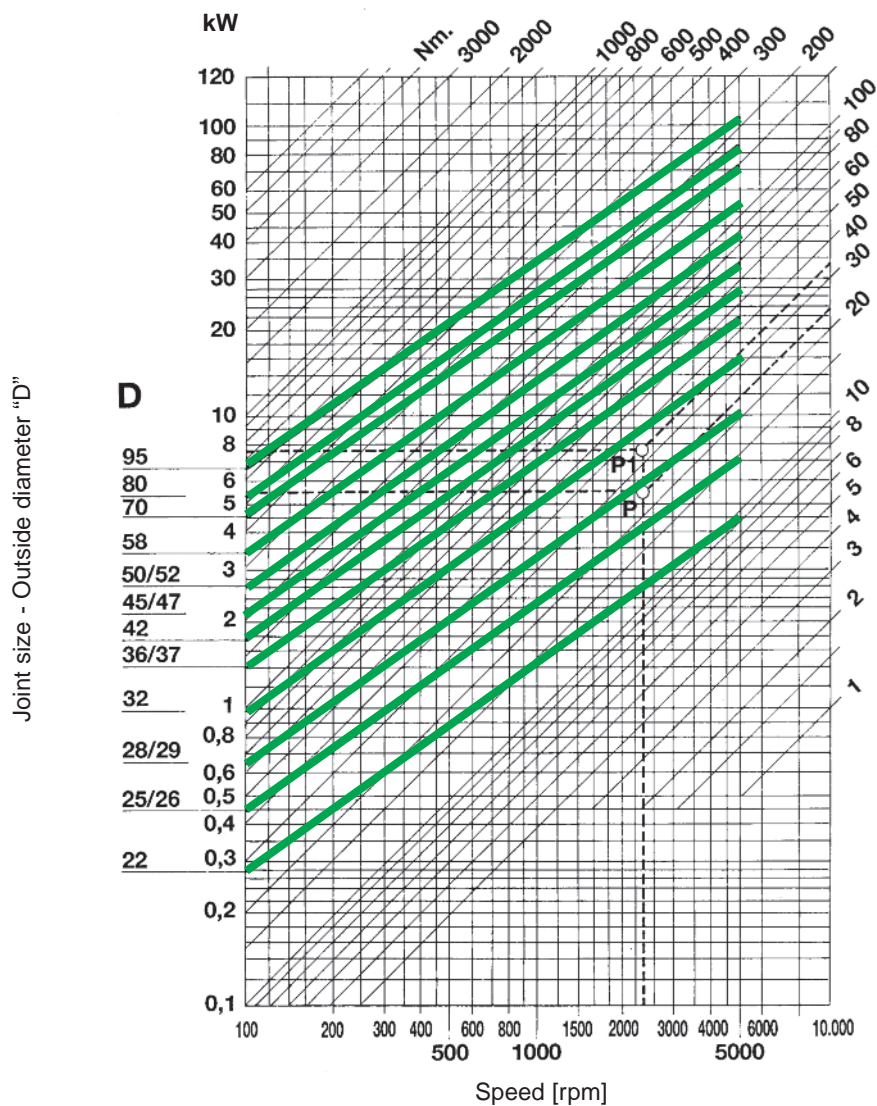

Torque  $M_T$  in [Nm]

WORKING ANGLE "α"	5°	10°	15°	20°	25°	30°	35°	40°	45°
CORRECTION FACTOR "F"	1,25	1,00	0,90	0,80	0,70	0,50	0,40	0,30	0,25

### Example

- Power: 5,5 kW
- rpm: 2300 min<sup>-1</sup>
- With working angle  $\alpha = 10^\circ$ , Factor  $F = 1,00$  (5,5 kW : 1,00 = 5,5 kW) we get point P and Torque  $M_T = 23$  Nm corresponding to joint size  $D = 28/29$  mm (type 05H, 1HB)
- With working angle  $\alpha = 25^\circ$ , Factor  $F = 0,70$  (5,5 kW : 0,70 = 7,85 kW) we get point P1 and Torque  $M_T = 33$  Nm corresponding to joint size  $D = 32$  mm (type 1H, 3HB).

Consider that:

$$M_T = 9.550 \times \frac{\text{Power [kW]}}{\text{rpm [min}^{-1}\text{]}} \quad [\text{Nm}]$$

$$M_T = 7.020 \times \frac{\text{Power [CV]}}{\text{rpm [min}^{-1}\text{]}} \quad [\text{Nm}]$$

## Instructions for a correct fitting

Fig. 1

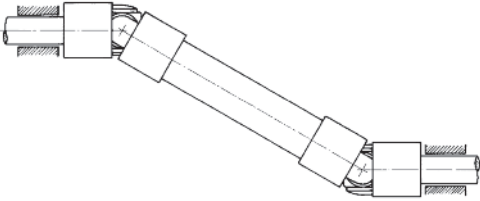
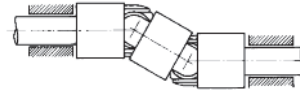

Fig. 2



To obtain a uniform rotary motion, always use two opposite single joints or one double joint. The pillow blocks must be positioned as close as possible to the joints (see Picture 1 and 2).

Fig. 3

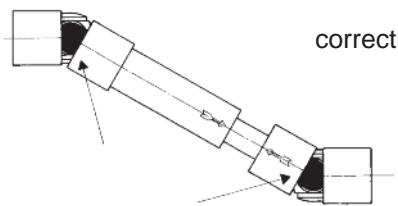
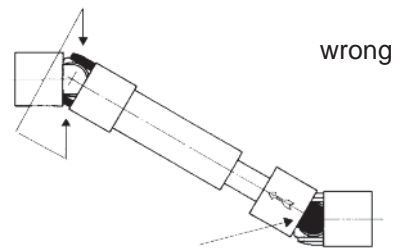

Fig. 4



When using two opposite single joints, respect the alignment of the inside yokes. In extensible transmissions also pay attention to the arrows stamped tally (see Picture 3 CORRECT, Picture 4 WRONG).

Fig. 5

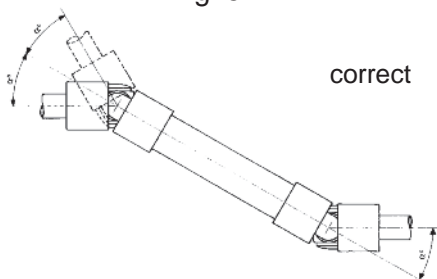
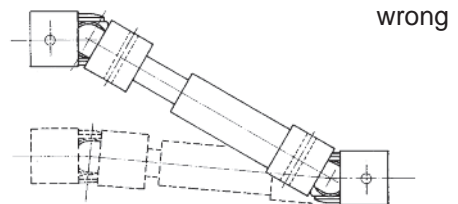

Fig. 6



The joints angle  $\alpha$  must be equal (see Picture 5). The shafts can be moved one from the other either parallel or symmetrically. Pin holes must not be executed over the yokes to avoid damage (see Picture 6).