

# Cast Steel Globe Valve

## Product Range:

Sizes	2"-12"
Pressure Class / Rating	Standard
Material of Construction	ASTM A216 WCB, ASTM A217 WC6, ASTM A351 CF8, ASTM A351 CF8M, ASTM A351 CF3, ASTM A351 CF3M
Trim	1 / 2 / 5 / 8 / 10 / 12
Mode of Operation	Manual ( Hand Wheel)

Figure:

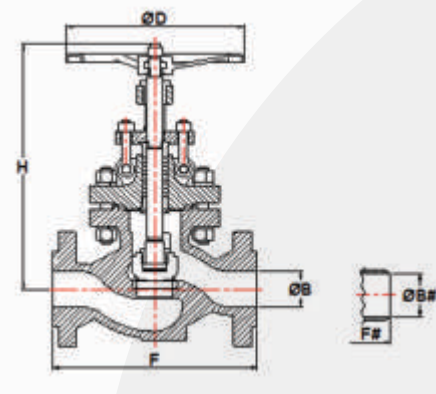

Table:

Globe Valve (Cast)							
Class	Sizes	F	Ø B	H	Ø D	F#	Ø B#
150	2"	203	51	365	205	203	51
	3"	241	77	440	255	241	78
	4"	292	102	470	355	292	102
	6"	406	153	585	355	406	154
	8"	495	204	695	455	495	203
	10"	662	254	885	510	622	254.5
	12"	698	305	985	575	698	305
300	2"	267	51	375	205	267	51
	3"	318	77	455	255	318	78
	4"	356	102	535	355	356	102
	6"	444	153	635	460	444	154
	8"	559	204	850	460	559	203
	10"	622	254	915	510	622	254.5
	12"	711	305	995	575	711	305
600	2"	292	51	425	255	292	51
	3"	356	77	505	355	356	73.5
	4"	432	102	580	355	432	97
	6"	559	153	795	510	559	146.5
	8"	660	204	930	620	660	193.5
	10"	787	254	1155	620	787	243
	12"	838	305	1215	700	838	289

Note: Class 900, 1500 & 2500 and sizes above 12" can be offered, Details shall be provided on request

## Design Features:

- ▲ Pressure Rating Class 150, 300, 600 as per ASME B16.34
- ▲ Bolted Bonnet Construction
- ▲ Complies to BS 1873
- ▲ Flat / Throttling Disc.
- ▲ Deep Stuffing Box
- ▲ Guided Disc
- ▲ Offer Carbon Steel, Stainless Steel, Alloy steel & Low temperature steel Material.
- ▲ 13%CR/Stellite Hard faced seats.
- ▲ Spiral Wound Gasket & Packing
- ▲ Testing as per API 598
- ▲ Corrugated / Graphite Gasket For Class 150

## Variants on Request:

- ▲ Lantern Ring Arrangement
- ▲ Special Class
- ▲ Throttling Disc
- ▲ Drain Plug
- ▲ Position Indicator
- ▲ Locking Arrangement
- ▲ Motorized Operation

# Forged Steel Globe Valve

## Product Range:

Sizes	1/2" - 2"
Pressure Class / Rating	Standard
Material of Construction	ASTM A105, ASTM A182 F22, ASTM A182 F304, ASTM A182 F304L, ASTM A182 F316, ASTM A182 F316L, ASTM A182 F51
Trim	1 / 2 / 5 / 8 / 10 / 12
Mode of Operation	Manual (Hand Wheel)

Figure:

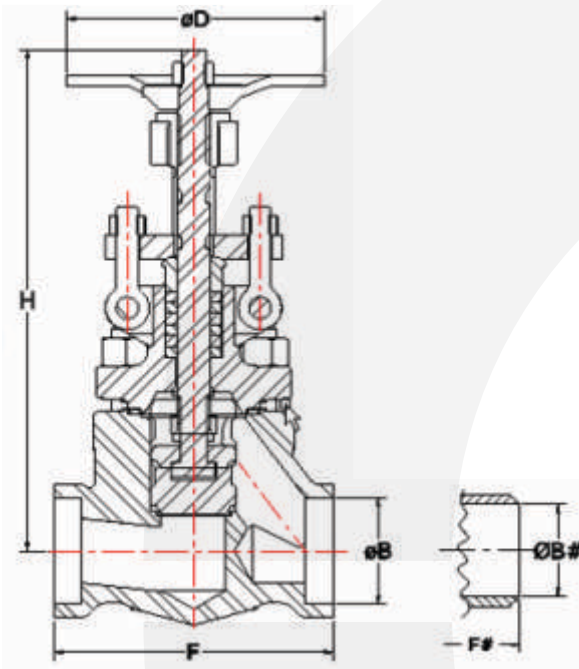

Table:

Globe Valve (Forged)							
Class	Sizes	F	ØB	H	ØD	F#	ØB#
800	1/2	78	21.8	179	110	78	12.7
	3/4	78	27.2	199	110	78	19.1
	1	100	33.9	212	110	100	25.4
	1¼	135	42.7	283	160	132	31.8
	1½	135	48.8	282	160	132	38.1
	2	160	61.2	316	160	160	50.8

Note: Class 1500 & 2500 can be offered, Details shall be Provided on request



## Design Features:

- ▲ Pressure Rating Class 800, 1500, 2500 as per ASME B16.34
- ▲ Bolted Bonnet Construction for class 800 & 1500
- ▲ Screwed, welded or pressure seal bonnet construction for Class 1500 & 2500
- ▲ Complies to API 602 & ISO - 15761
- ▲ Flat / Throttling Disc.
- ▲ Deep Stuffing Box
- ▲ Guided Disc
- ▲ Offer Carbon Steel, Stainless Steel, Alloy steel Material.
- ▲ Integral 13%CR/Stellite Hard faced seats.
- ▲ Spiral Wound Gasket & Packing
- ▲ Testing as per API 598

## Variants on Request:

- ▲ Flanged End Design to Class 150/300/600
- ▲ Special Class
- ▲ Throttling Disc
- ▲ Position Indicator
- ▲ Locking Arrangement
- ▲ Motorized Operation